

HUKX

Sensor
Technology

User manual
Pyrgeometer with heater

IR02

Warning statements



Putting more than 12 Volt across the sensor wiring can lead to permanent damage to the sensor.



Do not use "open circuit detection" when measuring the sensor output.

Contents

Introduction	5
1 Ordering and checking at delivery	7
1.1 Ordering IR20	7
1.2 Included items	7
1.3 Quick instrument check	8
2 Instrument principle and theory	9
2.1 Pyrgeometer functionality	9
2.2 Solar and longwave radiation	9
2.3 IR02 pyrgeometer design	11
2.4 Typical measurement results	12
2.5 Optional heating	12
2.6 Use as a net radiation sensor	12
3 Specifications of IR02	13
3.1 Specifications of IR02	13
3.2 Dimensions of IR02	18
4 Standards and recommended practices for use	19
4.1 Site selection and installation	20
4.2 Electrical connection	21
4.3 Requirements for data acquisition/amplification	22
5 Making a dependable measurement	23
5.1 The concept of dependability	23
5.2 Reliability of the measurement	24
5.3 Speed of repair and maintenance	25
5.4 Uncertainty evaluation	25
6 Maintenance and trouble shooting	27
6.1 Recommended maintenance and quality assurance	27
6.2 Trouble shooting	29
6.3 Calibration and checks in the field	30
6.4 Data quality assurance	30
7 IR02-TR	31
7.1 Introduction IR02-TR	31
7.2 Dimensions of IR02-TR	33
7.3 Electrical connection of IR02-TR	35
8 Appendices	37
8.1 Appendix on cable extension/replacement	37
8.2 Appendix on tools for IR02	38
8.3 Appendix on spare parts for IR02	38
8.4 Appendix on standards for classification and calibration	38
8.5 Appendix on calibration hierarchy	38
8.6 Appendix on meteorological radiation quantities	40
8.7 Appendix on terminology/glossary	41
8.8 EU declaration of conformity	43

List of symbols

quantities	symbol	unit
voltage output	U	V
sensitivity at reference conditions	S	V/(W/m ²)
temperature	T	°C
equivalent blackbody radiative temperature	T	°C
electrical resistance	R _e	Ω
longwave irradiance	E	W/m ²
Stefan-Boltzmann constant (5.67 x 10 ⁻⁸)	σ	W/(m ² ·K ⁴)

(see also Appendix 8.6 on meteorological quantities)

subscripts

sky	relating to the atmosphere
surface	relating to the ground surface
ambient	relating to ambient air
body	relating to the instrument body
sensor	relating to the sensor

Introduction

IR02 is a pyrgeometer used for longwave irradiance measurements in meteorological applications. The instrument can be heated, which improves measurement accuracy by mitigating dew and frost deposition on its window. Because of features like this, IR02 is popular and often used in agricultural networks.

IR02 measures the longwave or far-infrared radiation (FIR) received by a plane surface, in W/m^2 , from a field of view angle of approximately 150° .

Longwave radiation is the portion of atmospheric radiation not emitted by the sun. While the actual field of view angle is not the ideal 180° , the reduction makes it possible to offer IR02 at an attractive price level with only a minor loss in accuracy. IR02 has a window with a cut-on at $4.5 \times 10^{-6} m$, making it suitable for both day and night observations.

Benefits

IR02 pyrgeometer has a high sensitivity. With sufficient input signal a typical data logger no longer contributes to the uncertainty of the measurement. IR02 also houses an on-board heater. Heating prevents dew deposition and condensation which, when occurring, leads to very large measurement errors.

Operation

Using IR02 is easy. It can be connected directly to commonly used data logging systems. The irradiance in W/m^2 is calculated by dividing the IR02 output, a small voltage, by the sensitivity and taking in account the irradiated heat by the sensor itself (Stefan-Boltzmann law). The sensitivity is provided with IR02 on its product certificate.

The central measurement equation governing IR02 is:

$$E = U/S + \sigma \cdot (T + 273.15)^4 \quad (\text{Formula 0.1})$$

The instrument should be used in accordance with the recommended practices of the World Meteorological Organization (WMO).

Standards

Calibration of pyrgeometers used for downward longwave radiation is traceable to the World Infrared Standard Group (WISG). This calibration takes into account the spectral properties of downward longwave radiation.

As an option, calibration can be made traceable to a blackbody and the International Temperature Scale of 1990 (ITS-90). This alternative calibration is appropriate for measurements of upward longwave radiation (with IR02 pyrgeometers facing down).

IR02 design

IR02 pyrheliometer employs a thermal sensor with black coating, a flat silicon window with a solar-blind filter, and an anodized aluminum body.

Model IR02-TR houses a 4–20 mA transmitter for easy read-out by data loggers commonly used in the industry. For more information, see the chapter on IR02-TR.

Suggested use

- general meteorological observations
- climatological networks
- agricultural networks

Options

- longer cable, in multiples of 5 m
- **IR02-TR**, with 4–20 mA output

See also

- alternative instrument: **IR20** for higher-accuracy longwave radiation measurements
- **NR01** 4-component net radiometer, employing 2 pyrheliometers similar to IR02
- Pyrheliometers are often used in combination with pyranometers for solar radiation (shortwave) measurement. View our complete [product range of solar radiation sensors](#).

Figure 01 IR02 pyrheliometer with heater.



1 Ordering and checking at delivery

1.1 Ordering IR02

The standard configuration of IR02 is with 5 meters cable.

Common options are:

- longer cable (in multiples of 5 m). Specify total cable length.
- IR02-TR pyrgeometer with heater and 4 to 20 mA transmitter.
Standard setting is 4 mA at -300 W/m^2 and 20 mA at 100 W/m^2 .
Specify setting and total cable length.
- internal temperature sensor. This can be either a Pt100 (standard configuration) or a $10 \text{ k}\Omega$ thermistor (optional).
Specify T1 or T2, respectively.
- optional calibration to blackbody (ITS-90).

1.2 Included items

Arriving at the customer, the delivery should include:

- pyrgeometer IR02
- cable of the length as ordered
- product certificate matching the instrument serial number
- any other options as ordered

Please store the certificate in a safe place.

1.3 Quick instrument check

A quick test of the instrument can be done by using a simple handheld multimeter and a thermal source.

1. Check the electrical resistance of the sensor between the gray [-] and pink [+] wire. Use a multimeter at the 1000 Ω range. Measure the sensor resistance first with one polarity, than reverse the polarity. Take the average value. The typical resistance of the wiring is 0.1 Ω /m. Typical resistance should be the typical sensor resistance of 25 to 400 Ω plus 1.5 Ω for the total resistance of two wires (back and forth) of each 5 m. Infinite resistance indicates a broken circuit; zero or a low resistance indicates a short circuit.
2. Check if the sensor reacts to heat: put the multimeter at its most sensitive range of DC voltage measurement, typically the 100×10^{-3} VDC range or lower. Make sure that the sensor is at 25 $^{\circ}$ C or lower. Expose the sensor to a heat source at a short distance from the window of more than 50 $^{\circ}$ C, for instance, a heavy (> 5 kg) painted block of metal, or a painted metal container holding hot water. Face the side of the container to avoid condensation of water on the pyrgeometer window. Stir the water to attain homogeneity. A painted surface will act as a blackbody in the far infrared (FIR), irrespective of the visible color. The signal should read positive and $> 1 \times 10^{-3}$ V now. In case of using your hand as a heat source, the signal should be significantly lower.
3. Inspect the bubble level.
4. Check the electrical resistance of the Pt100. This should be in the 100 Ω range. In case of use of a 10 k Ω thermistor it should be in the 10^4 Ω range.
5. Check the electrical resistance of the heater. This should be in the 100 Ω range.
6. Inspect the instrument for any damage.

2 Instrument principle and theory

2.1 Pyrgeometer functionality

IR02's scientific name is pyrgeometer. IR02 measures the longwave or far infrared (FIR) radiation received by a plane surface, in W/m^2 , ideally from a 180° field of view angle. In meteorological terms pyrgeometers are used to measure "downward and upward longwave irradiance" (WMO definition). In case of IR02 the ideal 180° field of view angle has been reduced to 150° . This makes it possible to offer an instrument at an attractive price level, while the loss of accuracy is relatively small.

As secondary measurands, the sky temperature T_{sky} and the equivalent surface (ground) temperature T_{surface} can be measured. Both are so-called equivalent blackbody radiative temperatures, i.e. temperatures calculated from the pyrgeometer measurement assuming these are uniform-temperature blackbodies with an emission coefficient of 1.

2.2 Solar and longwave radiation

Longwave radiation is the part of the radiation budget that is not emitted by the sun. The spectral range of the longwave radiation is not standardized. A practical cut-on is in the range of 4 to 5×10^{-6} m (see Figure 2.2.1). In meteorology, solar and longwave radiation are typically measured as separate parameters. The instrument to measure solar radiation is called pyranometer.

In the longwave spectrum, the sky can be seen as a temperature source; colder than ground level ambient air temperature, with its lowest temperatures at zenith, getting warmer (closer to ambient air temperature) at the horizon. The uniformity of this longwave source is much better than that in the range of the solar spectrum, where the sun is a dominant contributor. The "equivalent blackbody" temperature, as a function of zenith angle, roughly follows the same pattern independent of the exact sky condition (cloudy or clear). This explains why for pyrgeometers the directional response is not very critical.

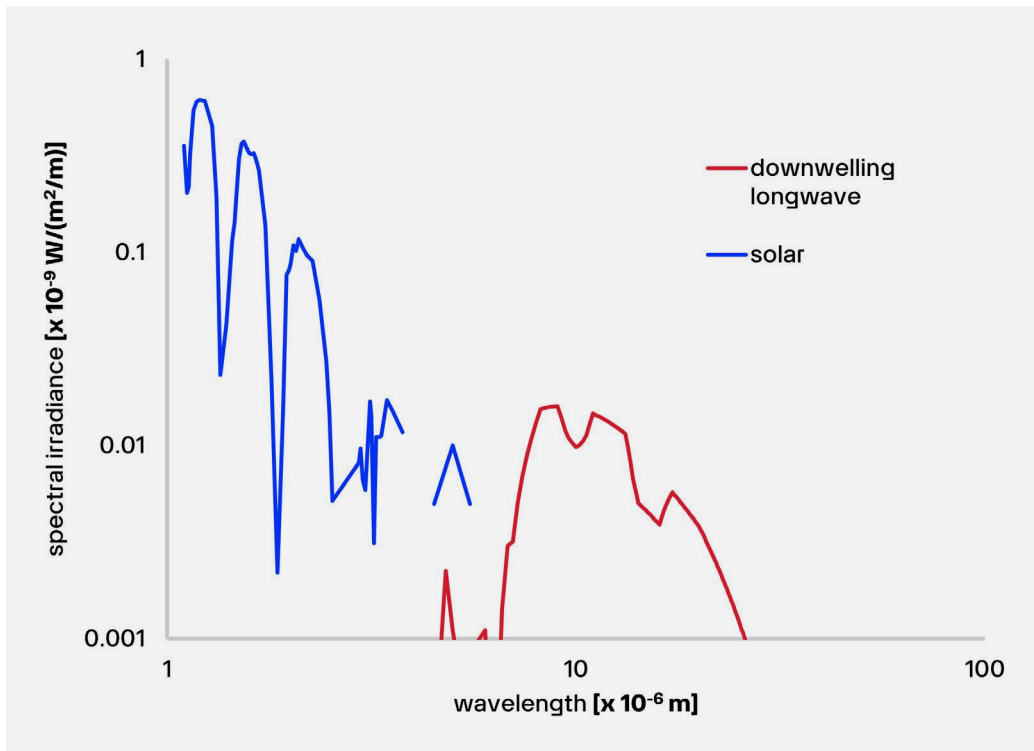

Figure 2.21 Atmospheric radiation as a function of wavelength plotted along two logarithmic axes to highlight the longwave radiation. Longwave radiation is mainly present in the 4 to 50 x 10⁻⁶ m range, whereas solar radiation is mainly present in the 0.3 to 3 x 10⁻⁶ m range. In practice, the two are measured separately using pyrgeometers and pyranometers.

The downwelling longwave radiation essentially consists of several components:

1. Low temperature radiation from the universe, filtered by the atmosphere. The atmosphere is transparent for this radiation in the so-called atmospheric window (roughly the 10 to 15 x 10⁻⁶ m wavelength range).
2. Higher temperature radiation emitted by atmospheric gasses and aerosols.
3. In presence of clouds or mist, the low temperature radiation from the universe is almost completely blocked by the water droplets. The pyrgeometer then receives the radiation emitted by the water droplets.

Upwelling longwave irradiance is measured with downfacing instruments. These are presumably looking directly at the surface (absorption and emission of the atmosphere is low over a short distance of around 2 m), which behaves like a normal blackbody.

Hukx suggests calibrating downfacing instruments against a blackbody rather than having WISG as a reference.

2.3 IR02 pyrgeometer design

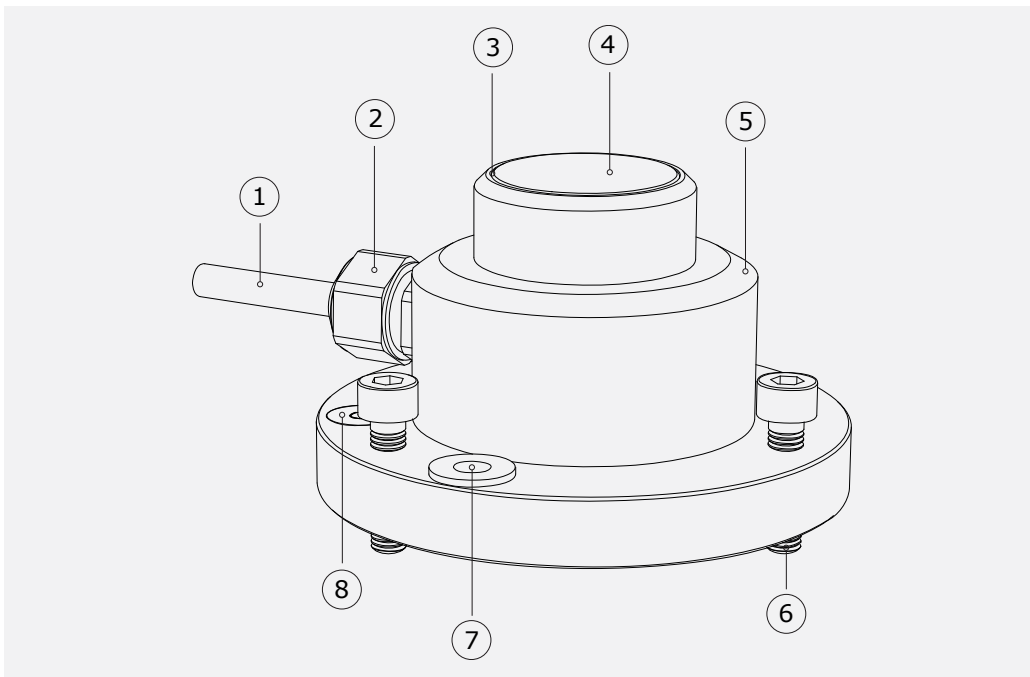

Figure 2.31
Overview of IR02 pyrgeometer:

1. cable
(standard length 5 meters,
optional longer cable)
2. cable gland
3. window with solar blind filter
4. sensor (below window)
5. sensor body
6. leveling feet
7. mounting hole
8. bubble level

By definition, a pyrgeometer should not measure solar radiation, and in the longwave have a spectral selectivity that is as “flat” as possible.

In an irradiance measurement by definition the response to “beam” radiation varies with the cosine of the angle of incidence; i.e. it should have full response when the radiation hits the sensor perpendicularly (normal to the surface, 0 ° angle of incidence), zero response when the source is at the horizon (90 ° angle of incidence, 90 ° zenith angle), and 50 % of full response at 60 ° angle of incidence.

A pyrgeometer should have a so-called “directional response” (older documents mention “cosine response”) that is as close as possible to the ideal cosine characteristic.

In order to attain the proper directional and spectral characteristics, a pyrgeometer’s main components are:

- A thermal sensor with black coating. It has a flat spectrum covering the 0.3 to 50×10^{-6} m range, and has a near-perfect directional response. The coating absorbs all longwave radiation and, at the moment of absorption, converts it to heat. The heat flows through the sensor to the sensor body. The thermopile sensor generates a voltage output signal that is proportional to the irradiance exchange between sensor and source. The sensor not only absorbs, but also irradiates heat as a blackbody.
- A silicon window. This dome limits the spectral range from 1.0 to 40×10^{-6} m (cutting off the part below 1.0×10^{-6} m), while preserving as much as possible the ideal 180 ° field of view angle. Another function of the window or dome is that it shields the thermopile sensor from the environment (convection, rain).
- A solar blind interference coating deposited on the window: this coating limits the spectral range. It now becomes 4.5 to 42×10^{-6} m (cutting off the part below 4.5×10^{-6} m).

Pyrgeometers can be manufactured to different specifications and with different levels of verification and characterization during production. Hukx also manufactures higher accuracy pyrgeometers; see pyrgeometer model [IR20](#).

2.4 Typical measurement results

Please note that the signal generated by an upfacing pyrgeometer usually has a negative sign. The most important factors determining downward longwave irradiance are:

- ambient air temperature
- sky condition/cloud cover
- atmospheric moisture content

Table 2.4.1 Expected pyrgeometer output U/S at different ambient air temperatures, T_{ambient} , and at different cloud conditions. Under clear sky conditions the U/S is around -100 W/m^2 while under cloudy conditions it will be close to 0 W/m^2 . Also calculated: the sky temperature, T_{sky} , and the longwave downward irradiance E.

Expected pyrgeometer output conditions				
T_{ambient}	sky condition	U/S	T_{sky}	E
[°C]	[cloudy], [clear]	[W/m ²]	[°C]	[W/m ²]
-20	cloudy	0	-20	232
-20	clear sky	-100	-53	132
0	cloudy	0	+0	314
0	clear sky	-100	-24	214
+30	cloudy	0	+30	477
+30	clear sky	-100	+12	377

2.5 Optional heating

A low-power heater is located in the body of the pyrgeometer. The heater is not necessarily switched on; recommended operation is to activate the heater when there is a risk of dew deposition.

2.6 Use as a net radiation sensor

Two pyrgeometers mounted back to back may be used to measure net longwave radiation. Net longwave radiation is defined as downwelling minus upwelling longwave irradiance. In case the two instruments are thermally coupled, the body temperatures of the instruments are identical. In that case the body temperature cancels from the equation for the net radiation. However for calculation of sky temperature and surface temperature the instrument temperature still needs to be measured. See also model [NR01](#), a 4-component net radiometer.

3 Specifications of IR02

3.1 Specifications of IR02

The IR02 pyrgeometer measures the longwave irradiance received by a plane surface, in W/m^2 , from a 150° field of view angle, which approximates the ideal 180° field of view angle. In meteorological terms, IR02 measures downward and upward longwave irradiance. Working completely passive, using a thermopile sensor, IR02 generates a small output voltage proportional to the radiation balance between the instrument and the source it faces. It can only be used in combination with a suitable measurement system. The instrument is not subject to classification. It should be used in accordance with the recommended practices of WMO. IR02 measures during both day and night. For high-accuracy measurements, the user should consider using the incorporated heater.

Table 3.1.1 Specifications of IR02 (continued on next pages).

IR02 specifications	
measurands	
measurand	longwave radiation
measurand in SI radiometry units	longwave irradiance in W/m^2
optional measurand	sky temperature
optional measurand	surface temperature
spectral range IR02	4.5 to 42×10^{-6} m
solar offset	$< 15 W/m^2$ (at $1000 W/m^2$ global horizontal irradiance on the dome)

main specifications

field of view angle	150 °
response time (95 %)	18 s
sensitivity (nominal)	$15 \times 10^{-6} \text{ V}/(\text{W}/\text{m}^2)$
sensitivity range	5 to $25 \times 10^{-6} \text{ V}/(\text{W}/\text{m}^2)$
rated operating temperature range	-40 to +80 °C
temperature dependence	$< \pm 3 \% (-10 \text{ to } +40 \text{ °C})$
temperature sensor	Pt100
required sensor power	zero (passive sensor)
heater	12 VDC, 1.5 W (see next pages for details)
standard cable length	5 m

Additional specifications

zero offset b (response to 5 K/h change in ambient temperature)	$< \pm 4 \text{ W}/\text{m}^2$
non-stability	$< \pm 1 \% \text{ change per year}$
non-linearity	$< \pm 2.5 \% (100 \text{ to } 300 \text{ W}/\text{m}^2, \text{ relative to } 200 \text{ W}/\text{m}^2 \text{ sensor to source exchange})$
measurement range	-300 to +300 W/m^2 (sensor to source exchange: U/S)
tilt dependence	$< \pm 2 \% (0 \text{ to } 90 \text{ ° at } 300 \text{ W}/\text{m}^2)$
sensor resistance range	25 to 400 Ω
expected voltage output	application for outdoor measurement of downward longwave irradiance: $-7.5 \text{ to } 7.5 \times 10^{-3} \text{ V}$
measurement function/required programming	$E = U/S + \sigma \cdot (T + 273.15)^4$
measurement function/optional programming for sky temperature	$T_{\text{sky}} = (E_{\downarrow}/\sigma)^{1/4} - 273.15$
measurement function/optional programming for surface temperature	$T_{\text{surface}} = (E_{\uparrow}/\sigma)^{1/4} - 273.15$

required read-out	1 differential voltage channel or 1 single ended voltage channel, input resistance > 10 ⁶ Ω 1 temperature channel
-------------------	---

Standards

standard governing use of the instrument	WMO-No. 8, <i>Guide to Meteorological Instruments and Methods of Observation</i> , seventh edition 2008, Paragraph 7.4 "measurement of total and longwave radiation"
--	--

Mounting, cabling, transport

standard cable length (see options)	5 m
-------------------------------------	-----

cable diameter	5.3 x 10 ⁻³ m
----------------	--------------------------

cable replacement	IR02 cable is potted and cannot be replaced
-------------------	---

instrument mounting	2 x M5 bolt at 65 x 10 ⁻³ m center-to-center distance on north-south axis
---------------------	--

leveling	Bubble level and adjustable leveling feet are included.
----------	---

leveling accuracy	< 0.4 ° bubble entirely in ring
-------------------	---------------------------------

IP protection class	IP67
---------------------	------

gross weight including 5 m cable	approx. 1 kg
----------------------------------	--------------

net weight including 5 m cable	approx. 0.5 kg
--------------------------------	----------------

Heating

heater operation	The heater is not necessarily switched on; recommended operation is to activate the heater when there is a risk of dew deposition.
------------------	--

required heater power	1.5 W at 12 VDC
-----------------------	-----------------

heater resistance	95 Ω
-------------------	------

steady state zero offset caused by heating	0 W/m ²
--	--------------------

Calibration

calibration traceability	to WISG
optional traceability	to blackbody (ITS-90)
calibration hierarchy	From WISG through Hukx internal calibration procedure employing a blackbody.
calibration method	Indoor calibration under a blackbody, by comparison reference pyrgeometer traceable to WISG.
calibration uncertainty	< 7 % (k = 2)
recommended recalibration interval	2 years
reference conditions	horizontal mounting, atmospheric longwave irradiance, clear sky nights, 20 °C
validity of calibration	Based on experience the instrument sensitivity will not change during storage. During use under exposure to solar radiation the instrument "non-stability" specification is applicable. Hukx recommends ITS-90 traceable calibration for upward longwave irradiance measurement.

Measurement accuracy

uncertainty of the measurement	Statements about the overall measurement uncertainty can only be made on an individual basis. See the chapter on uncertainty evaluation.
achievable uncertainty (95 % confidence level) daily totals	± 15 % (Hukx's own estimate)

Versions/options

longer cable, in multiples of 5 m

option code = total cable length

calibration

optional to blackbody (ITS-90)

4–20 mA transmitter

Creating a 4–20 mA output signal, option code = TR,
with adapted housing standard setting is 4×10^{-3} A
at -300 W/m^2 and 20×10^{-3} A at $+100 \text{ W/m}^2$
Heater and internal temperature sensor directly
connected to cable wire.
For specifications see the chapter on IR02-TR.

internal temperature sensor

Measuring the body temperature:
version code = T1 for Pt100 DIN class A,
version code = T2 for thermistor $10 \text{ k}\Omega$ at $25 \text{ }^\circ\text{C}$.

3.2 Dimensions of IR02

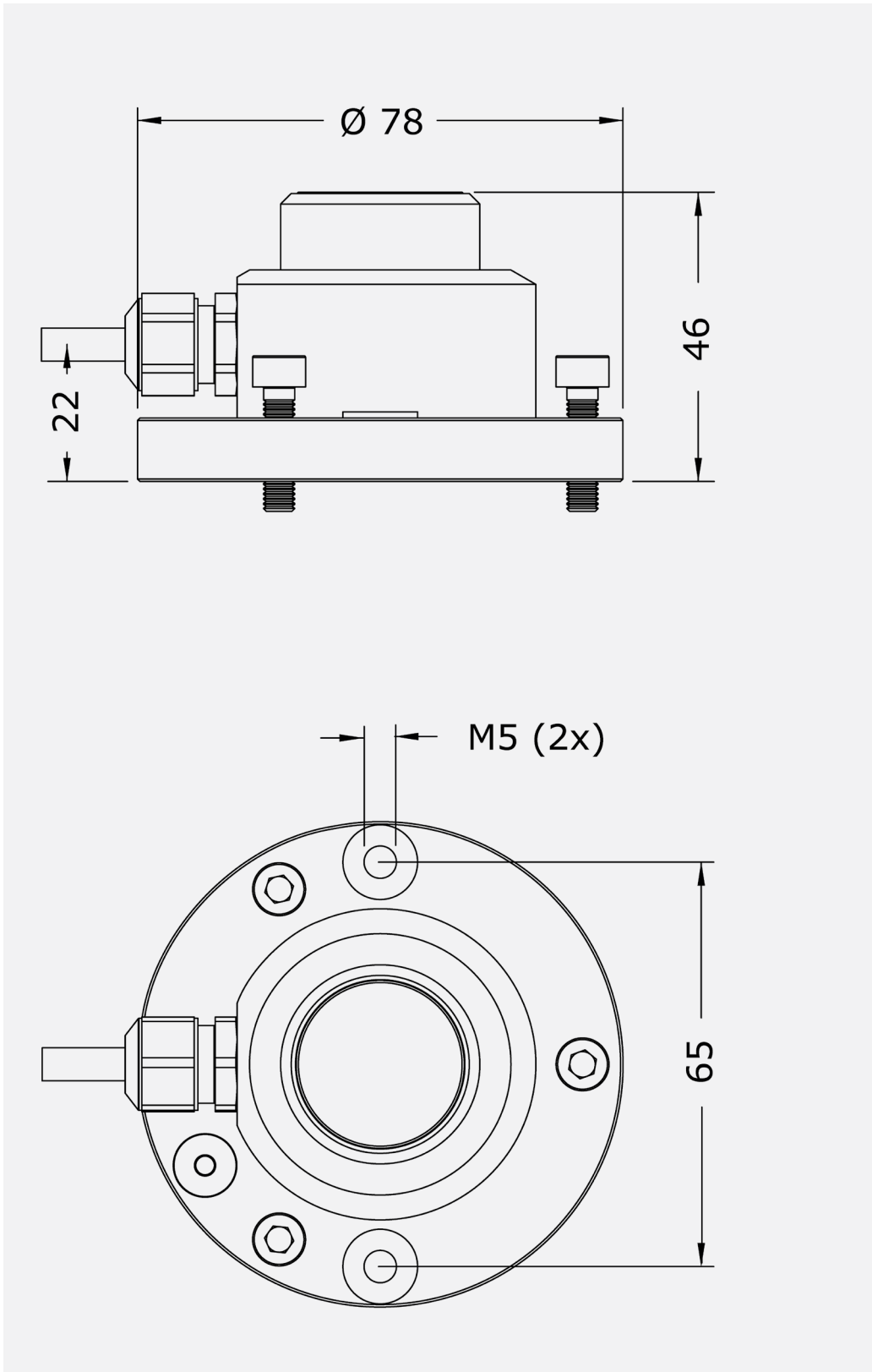

Figure 3.2.1 Dimensions of IR02
in 10^{-3} m.

4

Standards and recommended practices for use

Pyrgeometers are not subject to standardization.

The World Meteorological Organization (WMO) is a specialized agency of the United Nations. It is the UN system's authoritative voice on the state and behavior of the earth's atmosphere and climate. WMO publishes WMO-No. 8; *Guide to Meteorological Instruments and Methods of Observation*, in which Paragraph 7.4 covers "measurement of total and longwave radiation".

For ultra-high accuracy measurements, the following manual may serve as a reference: Baseline Surface Radiation Network (BSRN) Operations Manual, Version 2.1, L. J. B. McArthur, April 2005, WCRP-121, WMO/TD-No. 1274. This manual also includes chapters on installation (Paragraph 4.1) and calibration (Paragraph 8.4).

4.1 Site selection and installation

Table 4.1.1 Recommendations for installation of pyrgeometers.

location	The horizon should be as free from obstacles as possible.
mechanical mounting/ thermal insulation	Preferably use connection by bolts to the bottom plate of the instrument. A pyrgeometer is sensitive to thermal shocks. Do not mount the instrument with the body in direct thermal contact to the mounting plate (so always use the leveling feet also if the mounting is not horizontal), do not mount the instrument on objects that become very hot (black coated metal plates).
instrument mounting with 2 bolts	2 x M5 bolt at 65×10^{-3} m center-to-center distance on north-south axis, connection through the pyrgeometer flange.
performing a representative measurement	<p>The pyrgeometer measures the solar radiation in the plane of the sensor. This may require installation in a tilted or inverted position. The sensor surface (sensor bottom plate) should be mounted parallel to the plane of interest.</p> <p>In case a pyrgeometer is not mounted horizontally or in case the horizon is obstructed, the representativeness of the location becomes an important element of the measurement. See the chapter on uncertainty evaluation.</p>
leveling	In case of horizontal mounting only use the bubble level and leveling feet.
instrument orientation	By convention with the cable exit pointing to the nearest pole (so the cable exit should point north in the northern hemisphere, south in the southern hemisphere).
installation height	In case of inverted installation, WMO recommends a distance of 1.5 m between soil surface and sensor (reducing the effect of shadows and in order to obtain good spatial averaging).

4.2 Electrical connection

In order to operate, a pyrogeometer should be connected to a measurement system, typically a so-called data logger. IR02 is a passive sensor that does not need any power. Cables generally act as a source of distortion, by picking up capacitive noise. We recommend keeping the distance between a data logger or amplifier and the sensor as short as possible. For cable extension, see the appendix on this subject.

Table 4.2.1 The electrical connection of IR02. The heater is not necessarily used. The temperature sensor must be used.

PIN	wire	IR02
1	red	Pt100 [+]
2	white	Pt100 [+]
3	blue	Pt100 [-]
4	green	Pt100 [-]
5	brown	heater
6	yellow	heater
7	black	ground
8	pink	signal [+]
9	gray	signal [-]

Note 1: optional 10 kΩ thermistors are internally connected in a 4-wire configuration like the Pt100 but usually connected to electronics used in 2-wire configuration.

Note 2: the heater is not necessarily connected. In case it is connected, the polarity of the connection is not important.

Note 3: signal wires are insulated from ground wire and from the sensor body. Insulation resistance is tested during production and larger than $1 \times 10^6 \Omega$.

Note 4: ground is connected to the connector, the sensor body and the shield of the wire.

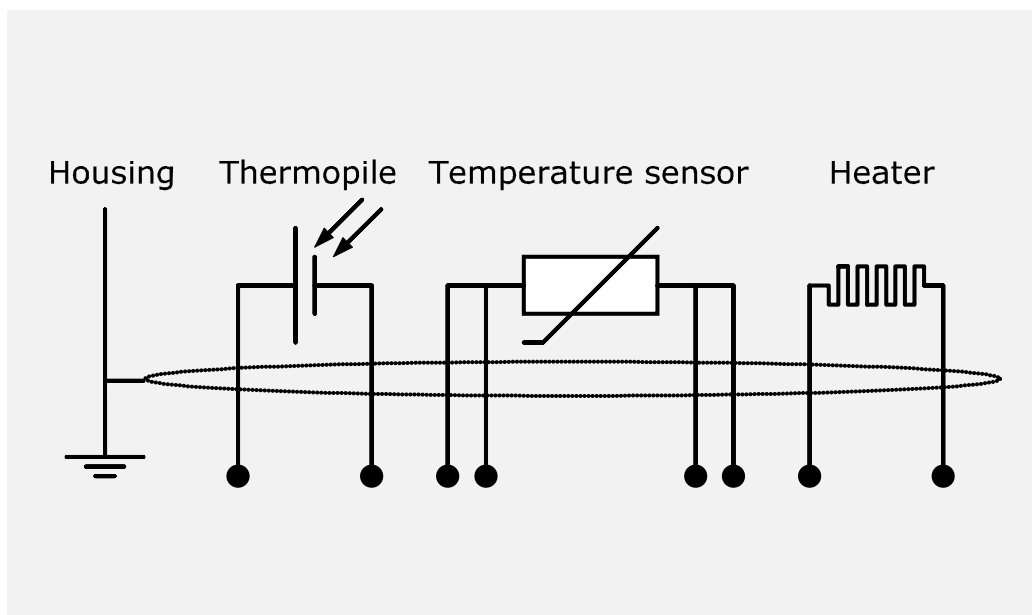

Figure 4.2.1 Electrical diagram of the internal wiring of IR02. The shield is connected to the sensor body.

4.3 Requirements for data acquisition/amplification

The selection and programming of data loggers is the responsibility of the user. Please contact the supplier of the data acquisition and amplification equipment to see if directions for use with the IR02 are available.

In case programming for similar instruments is available, this can typically also be used. IR02 can usually be treated in the same way as other thermopile pyrgeometers.

Table 4.3.1 Requirements for data acquisition and amplification equipment for IR02 in the standard configuration.

capability to measure small voltage signals	Preferably: better than 5×10^{-6} V uncertainty Minimum requirement: 20×10^{-6} V uncertainty (valid for the entire expected temperature range of the acquisition / amplification equipment)
capability for the data logger or the software	To store data, and to perform division by the sensitivity to calculate the longwave irradiance. $E = U/S + \sigma \cdot (T + 273.15)^4$ (Formula 0.1) (see also optional measurands)
data acquisition input resistance	$> 1 \times 10^6 \Omega$
open circuit detection (WARNING)	Open-circuit detection should not be used, unless this is done separately from the normal measurement by more than 5 times the sensor response time and with a small current only. Thermopile sensors are sensitive to the current that is used during open circuit detection. The current will generate heat, which is measured and will appear as an offset.
capability to measure temperature	A Pt100 (or optional thermistor) must be read-out. Required accuracy of the read-out is ± 0.2 °C, which results in around 1 W/m^2 uncertainty of the irradiance measurement.
capability to power the heater (OPTIONAL)	IR02 has a 12 VDC, 1.5 W heater on board, which may optionally be activated to keep the instrument above dew point. Some users prefer to have the heater on full time, others prefer to switch it on during nighttime only.

5

Making a dependable measurement

5.1 The concept of dependability

A measurement with a pyrgeometer is called "dependable" if it is reliable, i.e. measuring within required uncertainty limits, for most of the time and if problems, once they occur, can be solved quickly.

The requirements for a measurement with a pyrgeometer may be expressed by the user as:

- required uncertainty of the measurement (see following paragraphs)
- requirements for maintenance and repairs (possibilities for maintenance and repair including effort to be made and processing time)
- a requirement to the expected instrument lifetime (until it is no longer feasible to repair)

It is important to realize that the uncertainty of the measurement is not only determined by the instrument, but also by the way it is used.

In case of pyrgeometers, the measurement uncertainty as obtained during outdoor measurements is a function of:

- the instrument properties
- the calibration procedure/uncertainty
- the presence of natural sunlight (involving the instrument specification of solar offset)
- the measurement conditions (such as tilting, ventilation, shading, heating, instrument temperature)
- maintenance (mainly fouling and deposition of water)
- the environmental conditions* (such as temperature, position of the sun, presence of clouds, horizon, representativeness of the location)

Therefore, statements about the overall measurement uncertainty under outdoor conditions can only be made on an individual basis, taking all these factors into account.

* defined at Hukx as all factors outside the instrument that are relevant to the measurement such as the cloud cover (presence or absence of direct radiation), sun position, the local horizon (which may be obstructed) or condition of the ground (when inverted). The environmental conditions also involve the question whether or not the measurement at the location of measurement is representative of the quantity that should be measured.

5.2 Reliability of the measurement

A measurement is reliable if it measures within required uncertainty limits for most of the time. We distinguish between two causes of unreliability of the measurement:

- Related to the reliability of the pyrgometer and its design, manufacturing, calibration (hardware reliability).
- Related to the reliability of the measurement uncertainty (measurement reliability), which involves hardware reliability as well as condition of use.

Most of the hardware reliability is the responsibility of the instrument manufacturer. The reliability of the measurement however is a joint responsibility of instrument manufacturer and user. As a function of user requirements, taking into account measurement conditions and environmental conditions, the user will select an instrument of a certain class, and define maintenance support procedures.

In many situations, there is a limit to a realistically attainable accuracy level. This is due to conditions that are beyond control once the measurement system is in place. Typical limiting conditions are:

- The measurement conditions, for instance when working at extreme temperatures when the instrument temperature is at the extreme limits of the rated temperature range.
- The environmental conditions, for instance when installed at a sub-optimal measurement location with obstacles in the field of view.
- The environmental conditions, for instance when assessing net radiation, the downfacing pyrgometer measurement may not be representative of irradiance received in that particular area.

The measurement reliability can be improved by maintenance support. Important aspects are:

- Dome fouling by deposition of dust, dew, rain or snow. With pyrgometers, the most important source of unreliability is deposition of water on the dome. Water completely blocks the longwave radiation flux between sensor and sky. In particular at clear nights this causes very large errors. Water deposition under clear sky nighttime conditions can largely be prevented by using the instrument heater. Fouling results in undefined measurement uncertainty (sensitivity and directional error are no longer defined). This should be solved by regular inspection and cleaning.
- Sensor instability. Maximum expected sensor aging is specified per instrument as its non-stability in [% change/year]. In case the sensor is not recalibrated, the uncertainty of the sensitivity gradually will increase. This is solved by regular recalibration.
- Moisture condensing under pyrgometer domes resulting in a slow change of sensitivity (within specifications). For non-serviceable sensors like Hukx's flat window pyrgometers, such as model IR02, this may slowly develop into a defect. For research-grade model IR20 extra desiccant (in a set of 5 bags in an air-tight bag) is available.

– One of the larger errors in the daytime measurement of downwelling longwave irradiance is the offset caused by solar radiation; the “solar offset”. Errors due to solar offset, are of the order of $+15 \text{ W/m}^2$ at 1000 W/m^2 global horizontal irradiance. For ultra-high accuracy measurements this offset can be reduced by around 60 % by “shading”, which means preventing the direct radiation to reach the instrument. Shading is typically done by using a shading disk on a solar tracker. Shading is often applied with research-grade pyrgeometers like Hukx model IR20. The overall accuracy of model IR02 does not justify use of shading.

Another way to improve measurement reliability is to introduce redundant sensors.

– The use of redundant instruments allows remote checks of one instrument using the other as a reference, which leads to a higher measurement reliability.

5.3 Speed of repair and maintenance

Dependability is not only a matter of reliability but also involves the reaction to problems; if the processing time of service and repairs is short, this contributes to the dependability.

Hukx pyrgeometers are designed to allow easy maintenance and repair. The main maintenance actions are:

– Replacement of cabling and cable gland; please note that with IR02 the cable is potted inside the cable gland.

For optimization of dependability a user should:

- Estimate the expected lifetime of the instrument.
- Design a schedule of regular maintenance.
- Design a schedule of repair or replacement in case of defects.

When operating multiple instruments in a network, Hukx recommends keeping procedures simple and having a few spare instruments to act as replacements during service, recalibrations and repair.

5.4 Uncertainty evaluation

The uncertainty of a measurement under outdoor or indoor conditions depends on many factors, see Paragraph 1 of this chapter. It is not possible to give one figure for pyrgeometer measurement uncertainty. The work on uncertainty evaluation is “in progress”. There are several groups around the world participating in standardization of the method of calculation. The effort aims to work according to the guidelines for uncertainty evaluation (according to the “Guide to Expression of Uncertainty in Measurement” or GUM).

The main ingredients of the uncertainty evaluation for pyrgeometers are:

- Calibration uncertainty, which is in the order of $\pm 7\%$ ($k = 2$) for upfacing instruments measuring downward longwave irradiance
- Calibration uncertainty, which is larger for other than upfacing instruments; for downfacing instruments a blackbody calibration seems preferable. Blackbody calibration will result in a lower sensitivity, S , than WISG traceable calibration.
- Errors due to water deposition at clear nights; these completely block the longwave irradiance exchange between pyrgeometer and may cause the signal U/S to change from a large negative value (-100 W/m^2) to around 0 W/m^2 . Water deposition at clear nights may largely be avoided by using the on-board heater of IR02.
- Errors due to solar offset, which is of the order of $+15 \text{ W/m}^2$ at 1000 W/m^2 global horizontal irradiance. This uncertainty is not taken into account in the WISG calibration of the reference instrument.
- Errors due to the choice of the cut-on wavelength of the pyrgeometer. Depending on the atmospheric water content, the pyrgeometer will block a variable percentage of the downward longwave irradiance. This causes an uncertainty of the sensitivity S . With IR02, this uncertainty is already taken into account in the WISG calibration of the reference instrument.
- Errors due to instrument non-stability. This is now estimated at $< \pm 1\%$ change per year. The main factor in instrument non-stability is the aging of the pyrgeometer solar blind filter.
- Errors due to the temperature measurement T . For this a Pt100 or optional $10 \text{ k}\Omega$ thermistor must be read-out. Required accuracy of the read-out is $\pm 0.2 \text{ }^\circ\text{C}$, which results in around 1 W/m^2 uncertainty of the irradiance measurement. To this the uncertainty of the thermistor itself should be added. In measurement of net radiation, in case the upfacing and downfacing instruments are thermally coupled, the temperature measurement (and also its uncertainty) cancel from the equation.

6 Maintenance and trouble shooting

6.1 Recommended maintenance and quality assurance

IR02 can measure reliably at a low level of maintenance in most locations. Usually unreliable measurements will be detected as unreasonably large or small measured values. As a general rule this means that regular visual inspection combined with a critical review of the measured data, preferably checking against other measurements, is the preferred way to obtain a reliable measurement.

Table 6.1.1 Recommended maintenance of IR02. If possible the data analysis and cleaning (1 and 2) should be done on a daily basis. (continued on next page).

Minimum recommended pyranometer maintenance			
	interval	subject	action
1	1 week	data analysis	Compare measured data to maximum possible/ maximum expected irradiance and to other measurements nearby (redundant instruments). Also, historical seasonal records can be used as a source for expected values. Look for any patterns and events that deviate from what is normal or expected.
2	2 weeks	cleaning	Use a soft cloth to clean the dome of the instrument, persistent stains can be treated with soapy water or alcohol.
3	6 months	inspection	Inspect cable quality, inspect cable glands, inspect mounting position, inspect cable, clean instrument, clean cable, inspect leveling, change instrument tilt in case this is out of specification, inspect mounting connection.
4	2 years	recalibration	Recalibration by side-by-side comparison to a higher standard instrument in the field.
5		lifetime assessment	Judge if the instrument should be reliable for another 2 years, or if it should be replaced.

6	6 years	parts replacement	If applicable/necessary replace the parts that are most exposed to weathering; cable, cable gland, desiccant holder, sun screen. NOTE: use Hukx approved parts only.
7		internal inspection	If applicable: open instrument and inspect/replace O-rings; dry internal cavity around the circuit board
8		recalibration	rRcalibration by side-by-side comparison to a higher standard instrument at the manufacturer or a reference institute. Also, recalibrate the temperature sensor.

6.2 Trouble shooting

Table 6.2.1 Trouble shooting for IR02 (continued on the next page).

<p>The sensor does not give any signal.</p>	<p>Check the electrical resistance of the sensor between the (-) and (+) wire. Use a multimeter at the 1000 Ω range. Measure the sensor resistance first with one polarity, then reverse the polarity. Take the average value. The typical resistance of the wiring is 0.1 Ω/m. Typical resistance should be the typical sensor resistance of 25 to 400 Ω plus 1.5 Ω for the total resistance of two wires (back and forth) of each 5 m. Infinite resistance indicates a broken circuit; zero or a low resistance indicates a short circuit.</p> <p>Check if the sensor reacts to heat: put the multimeter at its most sensitive range of DC voltage measurement, typically the 100 x 10⁻³ VDC range or lower. Make sure that the sensor is at 25 °C or lower. Expose the sensor to a heat source at a short distance from the window of more than 50 °C, for instance, a heavy (> 5 kg) painted block of metal, or a painted metal container holding hot water. Face the side of the container to avoid condensation of water on the pyrgometer window. Stir the water to attain homogeneity. A painted surface will act as a blackbody in the far infrared (FIR), irrespective of the visible color. The signal should read positive and > 1 x 10⁻³ V now. In case of using your hand as a heat source, the signal should be significantly lower. Check the data acquisition by applying a 1 x 10⁻⁶ V source to it in the 1 x 10⁻⁶ V range.</p>
<p>The sensor signal is unrealistically high or low.</p>	<p>Check if the measurement function, has been implemented properly. Please note that each sensor has its own individual calibration factor and constants, as documented in its production certificate.</p> <p>Check the electrical resistance of the Pt100. This should be in the 100 Ω range. In case of use of the optional 10 kΩ thermistor it should be in the 104 Ω range.</p> <p>Check if the pyrgometer has a clean window.</p> <p>Check the location of the pyrgometer; are there any obstructions / sources that could explain the measurement result.</p> <p>Check the condition of the wiring at the logger.</p> <p>Check the cable condition looking for cable breaks.</p> <p>Check the range of the data logger; signal is usually negative (this could be out of range) or the amplitude could be out of range.</p> <p>Check the data acquisition by applying a 1 x 10⁻⁶ V source to it in the 1 x 10⁻⁶ V range. Look at the output. Check if the output is as expected.</p> <p>Check the data acquisition by short circuiting the data acquisition input with a 100 to 1000 Ω resistor. Look at the output. Check if it is close to 0 W/m².</p>
<p>The sensor signal shows unexpected variations.</p>	<p>Check the presence of strong sources of electromagnetic radiation (radar, radio etc.).</p> <p>Check the condition of the shielding.</p> <p>Check the condition of the sensor cable.</p> <p>Check if the cable is not moving during the measurement.</p>

The instrument shows internal condensation.	In case of condensation of droplets: disassemble the instrument and dry out the parts.
The instrument shows persistent internal condensation.	Arrange to send the sensor back to Hukx for diagnosis.

6.3 Calibration and checks in the field

Recalibration of field pyrgeometers is typically done by comparison in the field to a reference pyrgeometer. There is no standard for this procedure.

Hukseflux recommendation for re-calibration: if possible, perform calibration outdoor by comparison to an identical or a higher class reference instrument, under nighttime as well as daytime conditions. Use nighttime data only to determine S.

Hukx's main recommendations for field intercomparisons are:

1. Perform field calibration during several days; 2 to 3 days and if possible under cloudless conditions.
2. To take a reference of the same brand and type as the field pyrgeometer or a pyrgeometer of a higher class, and
3. To connect both to the same electronics, so that electronics errors (also offsets) are eliminated.
4. To mount all instruments on the same platform, so that they have the same body temperature.
5. To analyze downward irradiance values at nighttime only to determine S.
6. To analyze the daytime data, independently, and look at the residuals between the calibration reference and calibrated instrument as a function of solar irradiance. The solar offset can serve as a quality indicator of the pyrgeometer filter condition.

6.4 Data quality assurance

Quality assurance can be done by:

- Analyzing trends in longwave irradiance signal.
- Plotting the measured irradiance against mathematically generated expected values.
- Comparing irradiance measurements between sites.
- Analysis of daytime signals against solar irradiance.

The main idea is that one should look out for any unrealistic values. There are programs on the market that can semi-automatically perform data screening:

See for more information on such a program: <https://dama-nl.org/dqms-en>

7 IR02-TR

7.1 Introduction IR02-TR

As a version of IR02, Hukx offers model IR02-TR:
a pyrgeometer with heater and 4–20 mA transmitter.

IR02-TR houses a 4–20 mA transmitter for easy read-out
by data loggers commonly used in the industry.

Using IR02-TR is easy. The pyrgeometer can be connected directly
to commonly used data logging systems. The irradiance in W/m^2 is
calculated by using the transmitter's output and the temperature reading.
The latter can either be a Pt100 or a 10 k Ω thermistor, depending on the
ordered version.

In IR02-TR's standard configuration, the 4 to 20 mA output corresponds
to a transmitted range of -300 to $+100 W/m^2$. This range can be adjusted
at the factory upon request.



Figure 7.1: IR02-TR pyrgeometer
with heater and 4–20 mA
transmitter.

Table 7.1.1 Specifications of IR02-TR.

IR02-TR specifications	
description	pyrgeometer with heater and with 4–20 mA transmitter
transmitted range	-300 to +100 W/m ²
output signal	4 to 20 mA
principle	2-wire current loop
supply voltage	7.2 to 35 VDC
options	adapted transmitted range longer cable, in multiples of 5 m.
mounting	2 x M5 bolt at 65 mm center-to-center distance on north-south axis, or 1 x M6 bolt at the center of the instrument, connection from below under the bottom plate of the instrument

Table 7.1.2 Requirements for data acquisition and amplification equipment with the IR02-TR configuration.

IR02-TR specifications	
<p>capability to</p> <ul style="list-style-type: none"> - measure 4–20 mA or - measure currents or - measure voltages 	<p>The IR02-TR has a 4–20 mA output as well as a temperature sensor (see next row) which both must be read out. Concerning the 4–20 mA signal, there are several possibilities to handle this signal. It is important to realize that the signal wires not only act to transmit the signal but also act as power supply. Some data loggers have a 4–20 mA input. In that case the connection can be directly made. Some data loggers have the capability to measure currents. In some cases the data logger accepts a voltage input. Usually a 100 Ω precision resistor is used to convert the current to a voltage (this will then be in the 0.4 to 2 VDC range). This resistor must be put in the + wire of the sensor. In the two latter cases the user must check that the low side of the input channel is connected to ground, and the high side to a positive voltage in the required range. See the chapter on IR02-TR's electrical connections for wiring diagrams and electrical connections to am- and voltmeters.</p>
<p>capability to</p> <ul style="list-style-type: none"> - measure temperatures 	<p>Depending on the version this may be Pt100 or a 10 kΩ thermistor.</p>

7.2 Dimensions of IR02-TR

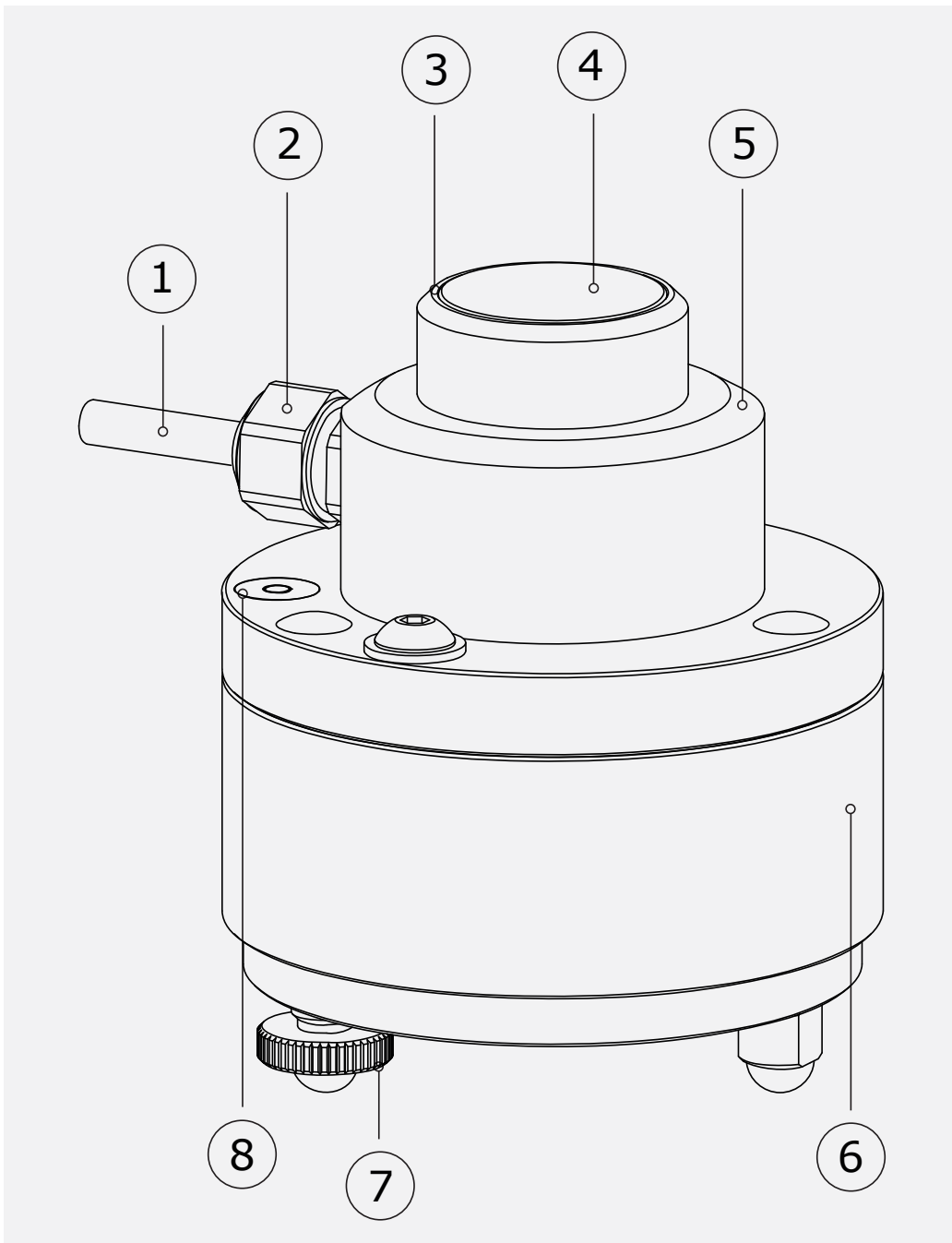

Figure 7.2.1 Overview of IR02-TR:

1. cable,
(standard length 5 meters,
optional longer cable)
2. cable gland
3. window with solar blind filter
4. sensor (below window)
5. sensor body
6. transmitter housing
7. leveling feet
8. bubble level

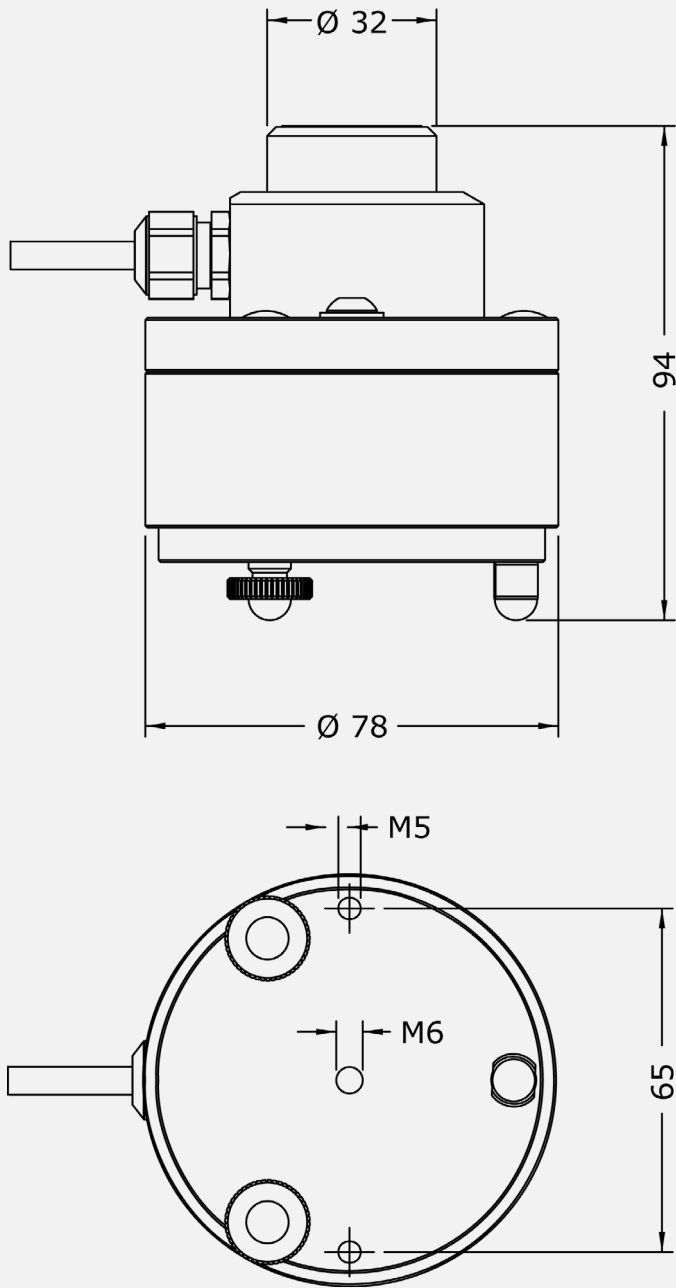

Figure 7.2.2 Dimensions of IR02-TR in 10^{-3} m.

7.3 Electrical connection of IR02-TR

In order to operate, a pyrogeometer should be connected to a measurement system, typically a so-called data logger. IR02-TR operates on a supply voltage of 7.2 to 35 VDC.

Table 7.3.1 The electrical connection of IR02-TR. The heater is not necessarily used. The temperature sensor must be used.

PIN	wire	IR02
1	red	Pt100 [+]
2	white	Pt100 [+]
3	blue	Pt100 [-]
4	green	Pt100 [-]
5	brown	heater
6	yellow	heater
7	black	ground
8	pink	signal [+]
9	gray	signal [-]

Note 1: optional 10 kΩ thermistors are internally connected in a 4-wire configuration like the Pt100, but usually connected to electronics used in 2-wire configuration.

Note 2: the heater is not necessarily connected. In case it is connected, the polarity of the connection is not important.

Note 3: signal wires are insulated from ground wire and from the sensor body. Insulation resistance is tested during production and larger than $1 \times 10^6 \Omega$.

Note 4: ground is connected to the connector, the sensor body and the shield of the wire.

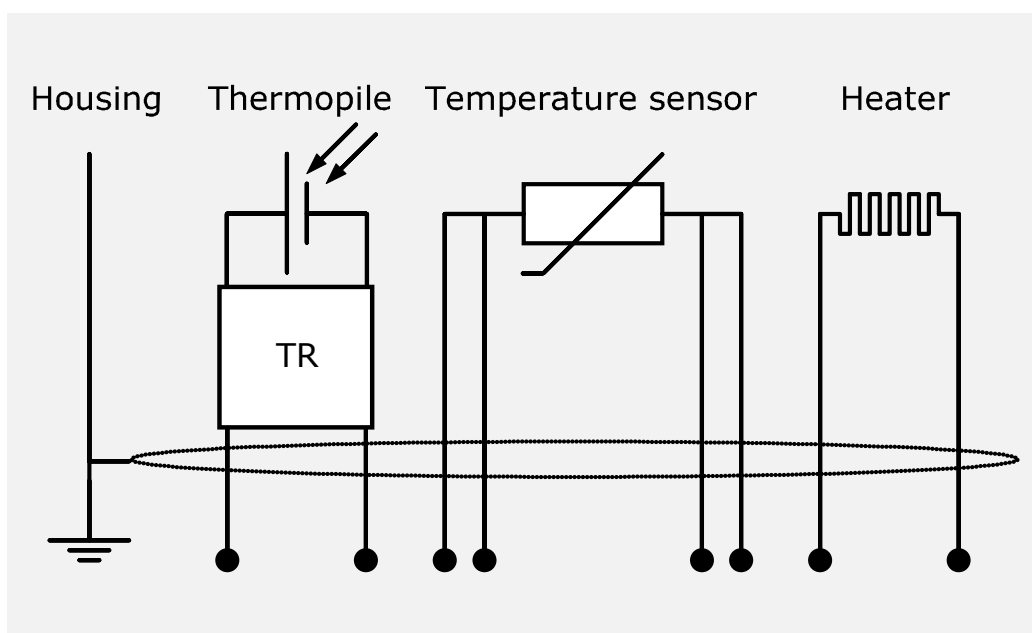

Figure 7.3.1 Electrical diagram of the internal wiring of IR02-TR. The shield is connected to the sensor body.

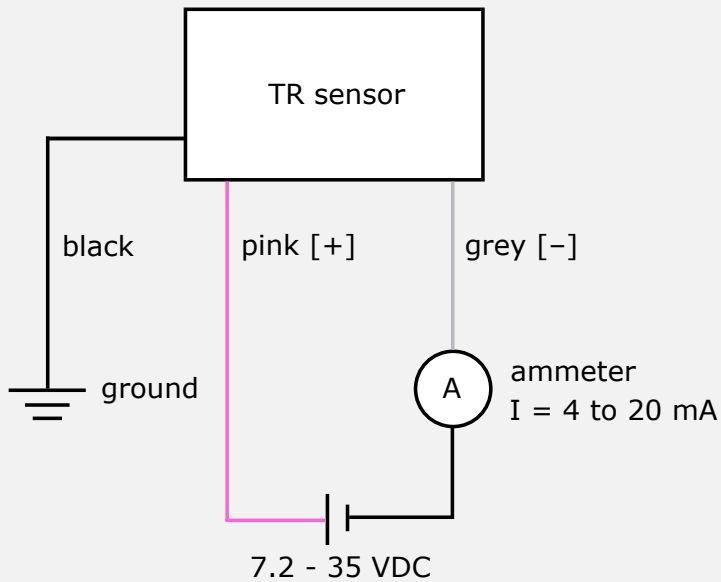

Figure 7.3.2 Electrical diagram of the connection of IR02-TR to a typical ammeter or data logger with the capacity to measure current signals. IR02-TR operates on a supply voltage of 7.2 to 35 VDC.

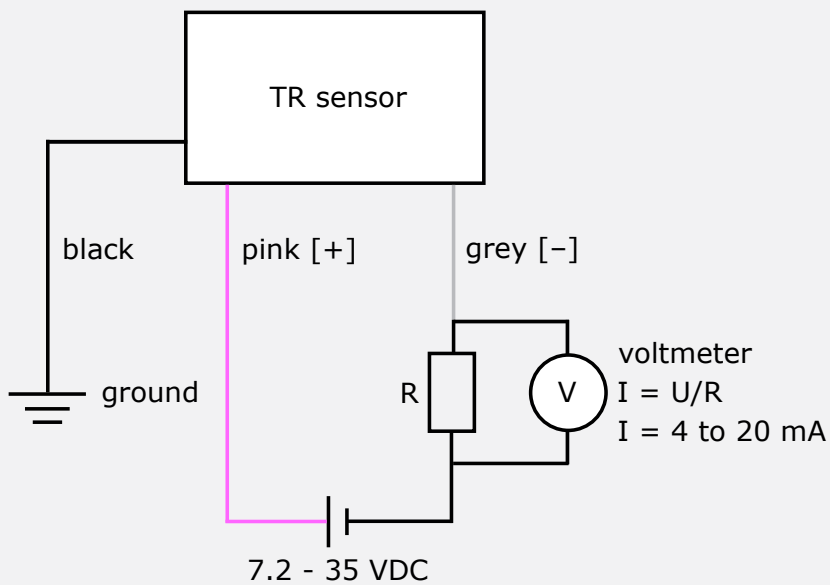

Figure 7.3.3 Electrical diagram of the connection of IR02-TR to a typical voltmeter or data logger with the capacity to measure voltage signals. Usually, a 100 Ω shunt resistor (R) is used to convert the current to a voltage. IR02-TR operates on a supply voltage of 7.2 to 35 VDC.

8 Appendices

8.1 Appendix on cable extension/replacement

IR02 cable is potted and cannot be replaced. The cable gland plus cable assembly may be completely removed and replaced by a similar assembly. Please consult Hukx for instructions on cable preparation or use Hukx-supplied parts.

IR02 is equipped with one cable. Keep the distance between data logger or amplifier and sensor as short as possible. Cables act as a source of distortion by picking up capacitive noise. In an electrically “quiet” environment the IR02 cable can however be extended without problem to 100 meters. If done properly, the sensor signal, although small, will not significantly degrade because the sensor resistance is very low (so good immunity to external sources) and because there is no current flowing (so no resistive losses). Cable and connection specifications are summarized below.

NOTE: the body of IR02 contains connector blocks that can be used for the internal connection of a new cable. See the chapter on electrical connections.

Table 8.1.1 Preferred specifications for cable extension of IR02.

general	Please consult Hukx for instructions or use Hukx-supplied parts.
cable	8-wire, shielded, with copper core
sealing	Sealed at the sensor side against humidity ingress.
core resistance	$< 0.1 \Omega/m$
length	Cables should be kept as short as possible, in any case, the total cable length should be less than 100 m.
outer sheet	Specified for outdoor use.
connection	Either solder the new cable core and shield to the original sensor cable, and make a waterproof connection using cable shrink, or use gold plated waterproof connectors. Always connect shield.

8.2 Appendix on tools for IR02

Table 8.2.1 Specifications of tools for IR02.

Tooling required for sun screen fixation and removal.	spanner size 15 mm
Tooling required for wire fixation and removal (internal wiring inside IR02 body).	screwdriver blade width 2 mm
Tooling for removal of bottom cap (locking plug).	plate for slot of 15 by 2 mm (5 EURO CENT coin)

8.3 Appendix on spare parts for IR02

- leveling feet (set of 3) (socket head cap screw M5 x 20, Aluminum)
- IR02 cable (specify length in multiples of 5 m) potted to cable gland
- bottom cap of IR02 with O-ring (locking plug M32 x 1.5 plus O-ring 47 x 2)

8.4 Appendix on standards for classification and calibration

Unlike pyranometers, pyrgeometers are not subject to a system of classification. At Hukx we distinguish between normal pyrgeometers, like model IR02, and “research grade” pyrgeometers, like IR20 and IR20WS. The term “research grade” is used to indicate that this instrument has the highest attainable specifications.

8.5 Appendix on calibration hierarchy

Hukx pyrgeometers are traceable to the World Infrared Standard Group (WISG). WISG is composed of a group of pyrgeometers. The calibration hierarchy of Hukx IR02 is from WISG through Hukx internal calibration procedures. The calibration of the IR02 working standard involves outdoor comparison at Hukx of the IR02 working standard to a working standard of a higher level, a pyrgeometer of model IR20 calibrated against the WISG. IR02 pyrgeometers are calibrated using an indoor procedure under an infrared source (blackbody).

The WISG group of instruments is maintained by World Radiation Center (WRC), in Davos Switzerland. An absolute sky-scanning radiometer provides the absolute longwave irradiance reference. Comparisons between the reference and the WISG are performed on a regular basis to maintain the WISG and supervise its long-term stability. It is essential that these intercomparisons take place under various sky conditions, but the predominant condition is a clear sky, which means that the validity of WISG calibration is a clear sky spectrum. Typical exchange between pyrgeometer and sky is in the -70 to -120 W/m².

Table 8.5.1 Calibration hierarchy for pyranometers with 150 ° field of view angle.

working standard IR20 calibration at PMOD / WRC davos

Calibration of working standard IR20 (180 ° field of view angle) pyrgeometers traceable to WISG.
A typical uncertainty of S is 4.2 % (k = 2).

correction of (working) standard IR20 calibration to standardized reference conditions

Correction from "test conditions of the standard" to "reference conditions":
No corrections are applied.

Reference conditions are: horizontal mounting, atmospheric longwave irradiance, clear sky nights, 20 °C.

outdoor working standard calibration at Hukx

Calibration of working standard (150 ° degrees field of view angle) pyrgeometer at Hukx.

indoor product calibration

Calibration of products, i.e. pyrgeometers of type IR02:

Method: Calibration according to Hukx internal procedure IRC. Indoor side by side comparison to a working standard IR02 pyrgeometer under an infrared blackbody source. This calibration has an uncertainty associated with the method.

calibration uncertainty calculation

ISO 98-3 Guide to the Expression of Uncertainty in Measurement, GUM Determination of combined expanded uncertainty of calibration of the product, including uncertainty of the working standard, uncertainty of correction, uncertainty of the method (transfer error). The coverage factor must be determined; at Hukx we work with a coverage factor k = 2.

Hukx specifies a calibration uncertainty of < 7 % (k = 2).

8.6 Appendix on meteorological radiation quantities

A pyrgeometer measures longwave irradiance. The time integrated total is called radiant exposure.

Table 8.6.1 Meteorological radiation quantities as recommended by WMO (additional symbols by Hukx). POA stands for Plane of Array irradiance. The term originates from ASTM and IEC standards.

symbol	description	calculation	units	alternative expression	
E_{\downarrow}	downward irradiance	$E_{\downarrow} = E_{g\downarrow} + E_{l\downarrow}$	W/m^2		
H_{\downarrow}	downward radiant exposure for a specified time interval	$H_{\downarrow} = H_{g\downarrow} + H_{l\downarrow}$	J/m^2		
E_{\uparrow}	upward irradiance	$E_{\uparrow} = E_{g\uparrow} + E_{l\uparrow}$	W/m^2		
H_{\uparrow}	upward radiant exposure for a specified time interval	$H_{\uparrow} = H_{g\uparrow} + H_{l\uparrow}$	J/m^2	$W \cdot h/m^2$	Change of units
E	direct solar irradiance normal to the apparent solar zenith angle		W/m^2	DNI	Direct Normal Irradiance
E_0	solar constant		W/m^2		
$E_{g\downarrow h}$	global irradiance; hemispherical irradiance on a specified, in this case, horizontal surface*	$E_{g\downarrow} = E \cdot \cos \theta_h + E_{d\downarrow}$	W/m^2	GHI	Global Horizontal Irradiance
$E_{g\downarrow t}$	global irradiance; hemispherical irradiance on a specified, in this case, tilted surface*	$E_{g\downarrow} = E \cdot \cos \theta_t + E_{d\downarrow t} + E_{r\uparrow t}$ ***	W/m^2	POA	Plane of Array
$E_{d\downarrow}$	downward diffuse solar radiation		W/m^2	DHI	Diffuse Horizontal Irradiance
$E_{l\uparrow}, E_{l\downarrow}$	upward/downward longwave irradiance		W/m^2		
$E_r\uparrow$	reflected solar irradiance		W/m^2		
E^*	net irradiance	$E^* = E_{\downarrow} - E_{\uparrow}$	W/m^2		
T_{surface}	equivalent blackbody radiative temperature of the surface**		$^{\circ}C$		
T_{sky}	equivalent blackbody radiative temperature of the sky**		$^{\circ}C$		
SD	sunshine duration			H	

θ is the apparent solar zenith angle θ_h relative to horizontal, θ_t relative to a tilted surface
 g = global, l = longwave, t = tilted *, h = horizontal*

* distinction horizontal and tilted from Hukx,
** T symbols introduced by Hukx,
*** contributions of $E_{d\downarrow t}$ and $E_{r\uparrow t}$ are $E_{d\downarrow}$ and $E_r\uparrow$ both corrected for the tilt angle of the surface

8.7 Appendix on terminology/glossary

Table 8.7.1 Definitions and references of used terms.

term	definition (reference)
solar energy or solar radiation	Solar energy is the electromagnetic energy emitted by the sun. Solar energy is also called solar radiation and shortwave radiation. The solar radiation incident on the top of the terrestrial atmosphere is called extra-terrestrial solar radiation; 97 % of which is confined to the spectral range of $(290 \text{ to } 3\,000) \times 10^{-9} \text{ m}$. Part of the extra-terrestrial solar radiation penetrates the atmosphere and directly reaches the earth's surface, while part of it is scattered and/or absorbed by the gas molecules, aerosol particles, cloud droplets and cloud crystals in the atmosphere. The former is the direct component, the latter is the diffuse component of the solar radiation (ref: WMO, Hukx).
hemispherical solar radiation	Solar radiation received by a plane surface from a 180° field of view angle (solid angle of $2\pi \text{ sr}$) (ref: ISO 9060).
global solar radiation	The solar radiation received from a 180° field of view angle on a horizontal surface is referred to as global radiation. Also called GHI. This includes radiation received directly from the solid angle of the sun's disc, as well as diffuse sky radiation that has been scattered in traversing the atmosphere (ref: WMO). Hemispherical solar radiation received by a horizontal plane surface (ref: ISO 9060).
Plane of Array irradiance	Also POA: hemispherical solar irradiance in the plane of a PV array (ref: ASTM E2848-13 / IEC 61724).
direct solar radiation	Radiation received from a small solid angle centered on the sun's disc, on a given plane (ref: ISO 9060).
terrestrial or longwave radiation	Radiation not of solar origin but of terrestrial and atmospheric origin and having longer wavelengths $(3\,000 \text{ to } 100\,000) \times 10^{-9} \text{ m}$. In case of downwelling E_{\downarrow} , also the background radiation from the universe is involved, passing through the "atmospheric window". In case of upwelling E_{\uparrow} , composed of longwave electromagnetic energy emitted by the earth's surface and by the gases, aerosols and clouds of the atmosphere; it is also partly absorbed within the atmosphere. For a temperature of 300 K, 99.99 % of the power of the terrestrial radiation has a wavelength longer than $3\,000 \times 10^{-9} \text{ m}$ and about 99 per cent longer than $5\,000 \times 10^{-9} \text{ m}$. For lower temperatures, the spectrum shifts to longer wavelengths (ref: WMO).
World Radiometric Reference (WRR)	Measurement standard representing the SI unit of irradiance with an uncertainty of less than $\pm 0.3\%$ (see the WMO Guide to Meteorological Instruments and Methods of Observation, 1983, subclause 9.1.3). The reference was adopted by the World Meteorological Organization (WMO) and has been in effect since 1 July 1980 (ref: ISO 9060).

albedo	Ratio of reflected and incoming solar radiation. Dimensionless number that varies between 0 and 1. Typical albedo values are: < 0.1 for water, from 0.1 for wet soils to 0.5 for dry sand, from 0.1 to 0.4 for vegetation, up to 0.9 for fresh snow.
angle of incidence	Angle of radiation relative to the sensor measured from normal incidence (varies from 0° to 90°).
zenith angle	Angle of incidence of radiation, relative to zenith. Equals angle of incidence for horizontally mounted instruments.
azimuth angle	Angle of incidence of radiation, projected in the plane of the sensor surface. Varies from 0 ° to 360 °. 0 is by definition the cable exit direction, also called north, east is +90 ° (ASTM G113-16).
sunshine duration	Sunshine duration during a given period is defined as the sum of that sub-period for which the direct solar irradiance exceeds 120 W/m ² (ref: WMO).
WISG	World Infrared Standard Group. Group of pyrgeometers, maintained by PMOD Davos Switzerland that forms the reference for calibration of pyrgeometers. WISG is traceable to international standards through an absolute sky scanning radiometer. WISG has been formally recognized by the World Meteorological Organization WMO as "interim WMO Pyrgeometer Infrared Reference".
sky temperature	equivalent blackbody radiative temperature of the sky; i.e. the temperature calculated from pyrgeometer data measuring downwelling longwave radiation, assuming the sky behaves as a blackbody with an emission coefficient of 1.
surface temperature	equivalent blackbody radiative temperature of the surface; i.e. the temperature calculated from pyrgeometer data measuring upwelling longwave radiation, assuming the ground behaves as a blackbody with an emission coefficient of 1.

8.8 EU declaration of conformity

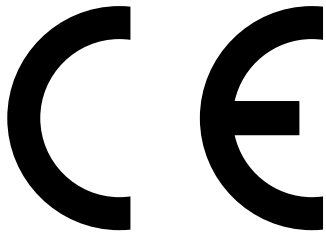

We, Hukseflux Thermal Sensors B.V.,
Delftechpark 31, 2628 XI, Delft,
The Netherlands

in accordance with the requirements of the following directive:

2014/30/EU The Electromagnetic Compatibility Directive

hereby declare under our sole responsibility that:

Product model	IR02
Product type	Pyrgeometer
Brand name	Hukx

has been designed to comply and is in conformity with the relevant sections and applicable requirements of the following standards:

Emission	EN 61326-1 (2006)
Immunity	EN 61326-1 (2006)
Emission	EN 61000-3-2 (2006)
Emission	EN 61000-3-3 (1995) + A1 (2001) + A2 (2005).
Report	08C01340RPT01, 06 January 2009

A handwritten signature in black ink, appearing to read 'Kees Van Den Bos', written over a horizontal line.

Kees VAN DEN BOS
Director
Delft, 20 April, 2016

About Hukx

Hukx is the leading innovator in solar radiation and heat flux sensor technology. We are proud to set the standard in high-accuracy measurement, and to be working at the heart of the energy transition.

Customers worldwide rely on our bestselling pyranometers and heat flux sensors. From sensor design and selection to supply and recalibration, we support you across the entire lifecycle.

Hukx is headquartered in the Netherlands, with locally owned representative sales offices in the USA, Brazil, India, China, Southeast Asia, and Japan.

Let us help you select the best sensor for your application. Get in touch with our experts today via: info@hukx.com

© Hukx

v2510

We reserve the right to change specifications without prior notice.

www.hukx.com

HUKX